

Panasonic

Operating Instructions

Dome Cover

Model No. **WV-CS4SA**

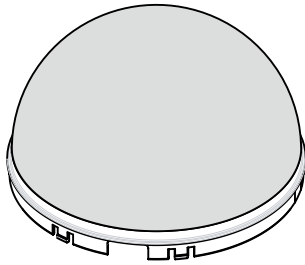

Before attempting to connect or install this product, please read these instructions carefully and save this manual for future use.

Precautions

- Do not attach the dome cover if the camera is mounted on the ceiling. Doing so may result in an injury if the dome cover falls.
- Do not remove the protective sheet until the camera has been installed in position to prevent scratches during installation.

Mounting procedures

- 1 Push the tab in the square hole on the camera with a tapered tool such as tweezers. With maintaining this state, rotate the dome fix ring counterclockwise, removing the dome fix ring and dome cover.

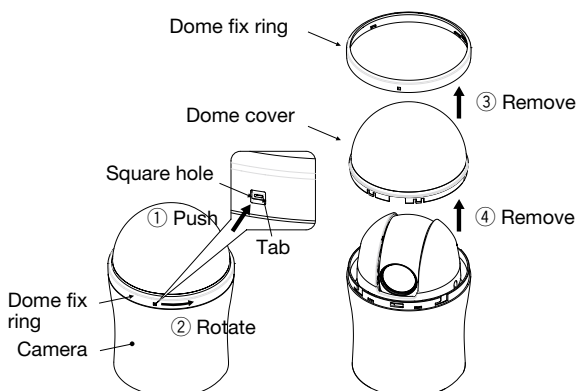

- 2 Align the hook on the dome cover (smoke type) and the grappling hole on the camera, installing the dome cover.

Note:

- Remove the edge of the protective sheet temporarily. It may prevent the dome fix ring from being installed. Leave the protective sheet attached until you install the camera after fixing the dome ring in order to prevent the dome from being damaged or getting dust.

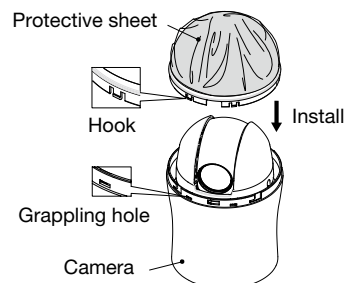

- 3** Install the dome fix ring.
Align the ▼ inside of the dome fix ring and the arrow of the camera, inserting the dome fix ring.
Then turn it clockwise, fixing the dome fix ring.

- 4** Install the camera and remove the protective sheet.
See the camera installation guide for further information.

Important:

- Turn the dome fix ring to the left and right to make sure it's firmly fixed.
Also make sure the tab is placed properly in the square hole.
Failure to fix it properly may drop the dome cover.

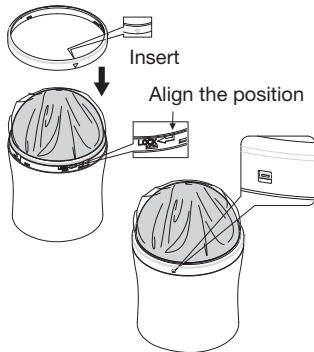

Specifications

Ambient operating temperature:	-10 °C - 50 °C {14 °F - 122 °F}
Mass:	Approx. 65 g {0.14 lbs.}
Dimensions:	129 mm (W) x 77 mm (H) x 125 mm (Dome dia.) {5-3/32 inches (W) x 3-1/32 inches (H) x 4-29/32 inches (Dome dia.)}

**Panasonic System Communications
Company of North America,
Unit of Panasonic Corporation of North America**
www.panasonic.com/business/
For customer support, call 1.800.528.6747
Two Riverfront Plaza, Newark, NJ 07102-5490

Panasonic Canada Inc.
5770 Ambler Drive, Mississauga, Ontario, L4W 2T3 Canada
(905)624-5010
www.panasonic.ca